

- D** Doormaster Smart FTZ Kurzbedienungsanleitung
- GB** Doormaster Smart FTZ quick guide
- I** Doormaster Smart FTZ guida rapida

## SIEDLE PVG 402-01

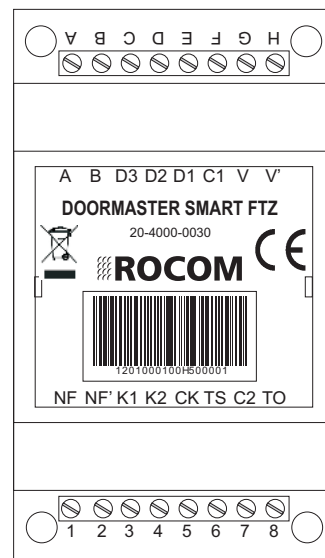

## SIEDLE PVG 602-01

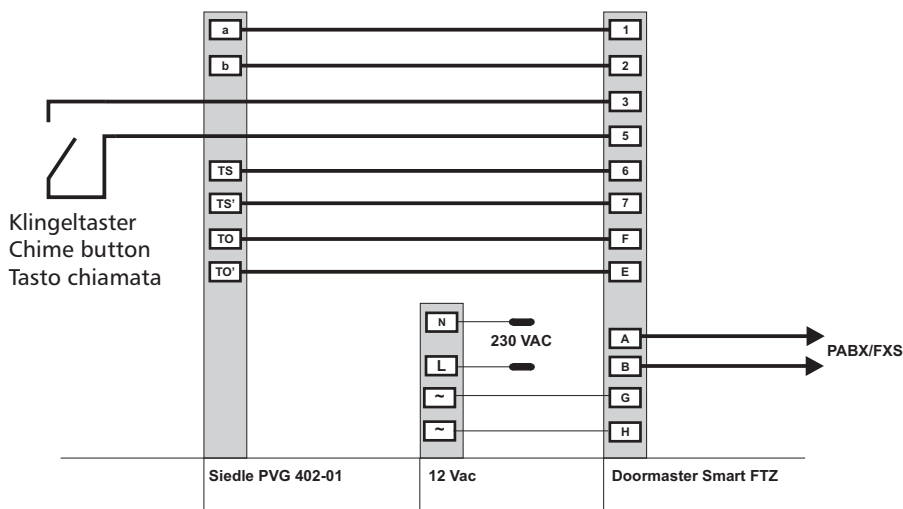
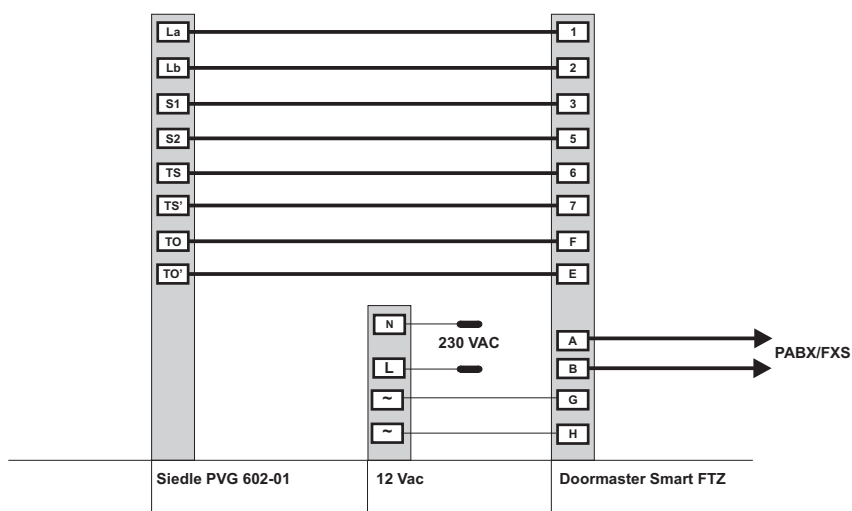

## RITTO TFV 4680/00

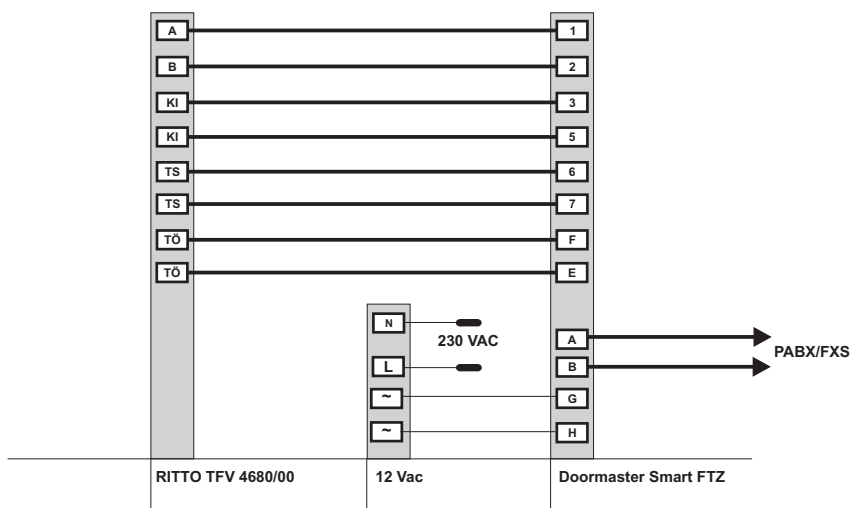

# ROCOM

- D** Doormaster Smart FTZ Programmierung
- GB** Doormaster Smart FTZ programming
- I** Doormaster Smart FTZ programmazione

## Programmiermodus aktivieren/activate programming mode/attivazione modalità programmazione



## Grunddaten laden/load factory set up/carica dati di fabbrica



## Programmierung der Rufnummern/telephon no. programming(programmazione nr. di telefono

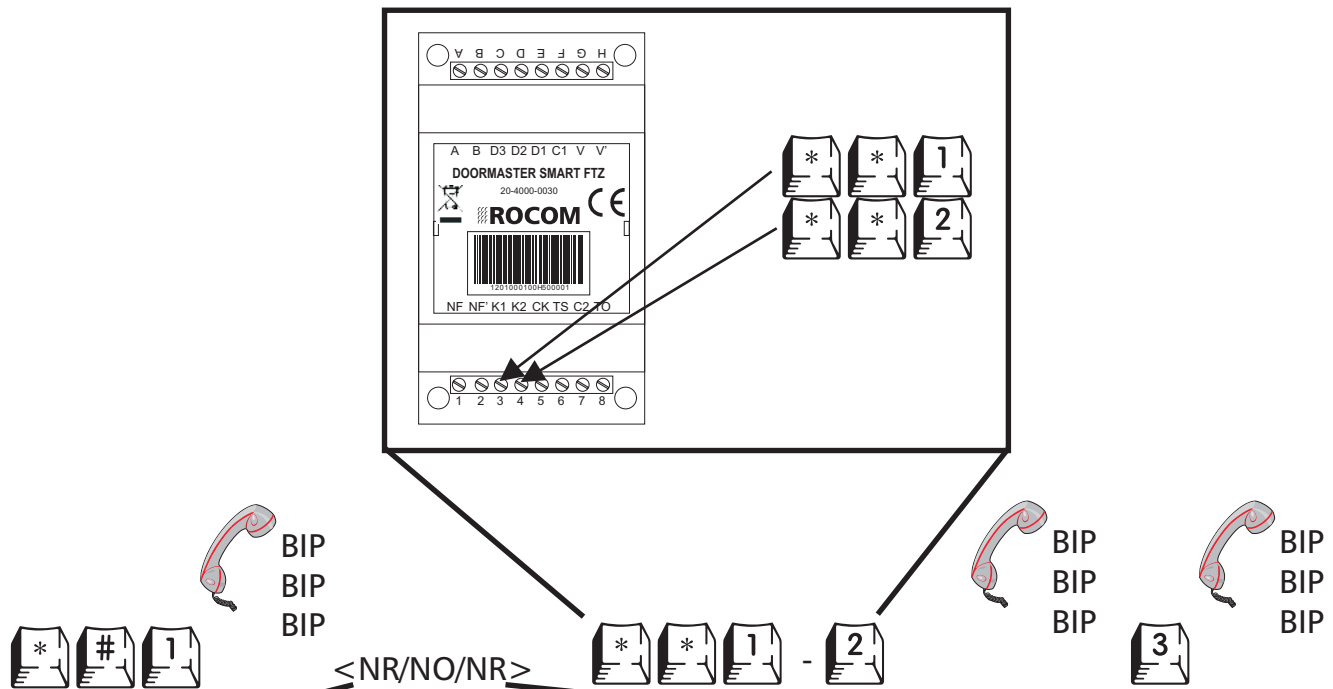

|   |                       |   |       |                       |         |
|---|-----------------------|---|-------|-----------------------|---------|
| 1 | wählt/dials/seleziona | 1 | 8     | wählt/dials/seleziona | 8       |
| 2 | wählt/dials/seleziona | 2 | 9     | wählt/dials/seleziona | 9       |
| 3 | wählt/dials/seleziona | 3 | 0     | wählt/dials/seleziona | 0       |
| 4 | wählt/dials/seleziona | 4 | # # 1 | wählt/dials/seleziona | #       |
| 5 | wählt/dials/seleziona | 5 | # # 2 | wählt/dials/seleziona | *       |
| 6 | wählt/dials/seleziona | 6 | # # 3 | wählt/dials/seleziona | "PAUSE" |
| 7 | wählt/dials/seleziona | 7 | # # 4 | wählt/dials/seleziona | R       |

- D** Doormaster Smart FTZ Programmierung
- GB** Doormaster Smart FTZ programming
- I** Doormaster Smart FTZ programmazione

## Telefonnummer löschen/delete a telephone no./cancellazione nr. telefonico



## Tonplan/progress tone plan/piano toni

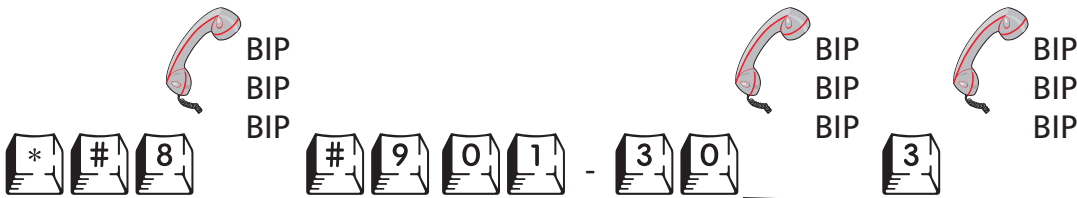

|                              |               |                    |                |
|------------------------------|---------------|--------------------|----------------|
| 01 = GER, ITA, MEX, POL, LUX | 05 = SPA, FRA | 09 = USA, CAN, TUR | 13 = T-Com     |
| 02 = SWE, DEN, ISL, POR      | 06 = SIN      | 10 = Agfeo         | 14 = Tenovis   |
| 03 = AUT, FIN, GRE, HUN      | 07 = BEL      | 11 = Panasonic     | 15 = Auerswald |
| 04 = GBR, AUS                | 08 = CZE      | 12 = Siemens       | 16 = Gesko     |

## Bedienungsanleitung/user guide/guida all'uso

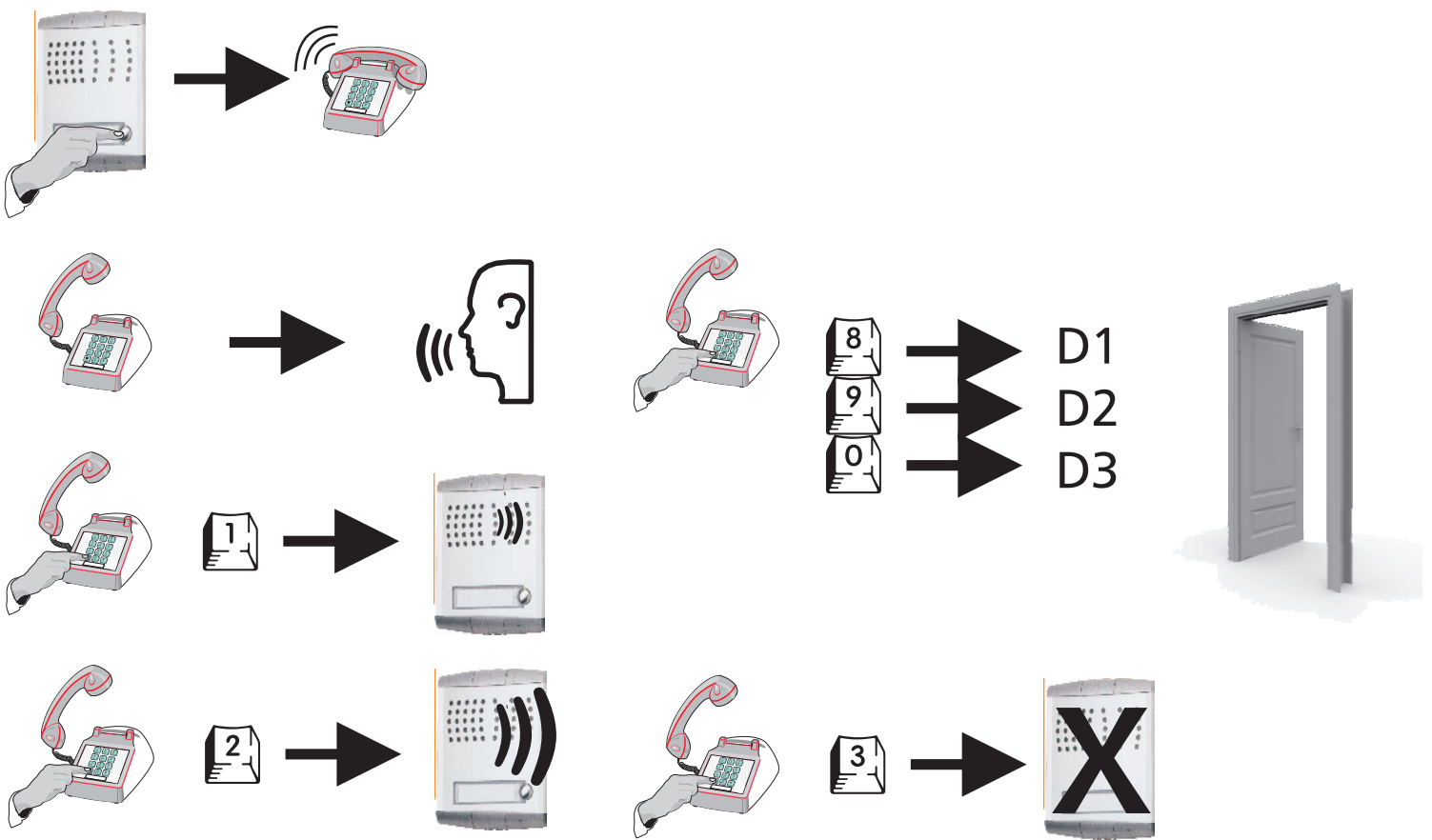

- D** Doormaster Smart FTZ technische Daten
- GB** Doormaster Smart FTZ technical data
- I** Doormaster Smart FTZ dati tecnici

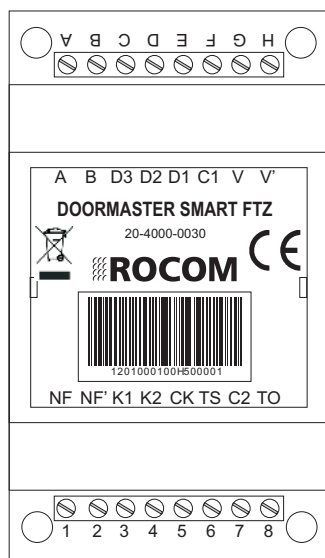

## **D** Doormaster Smart FTZ Anschlussklemmen

NF/NF' (1/2) : Sprech/Hören 600 Ohm  
 K1 (3): Klingeltaste 1 (potentialfrei)  
 K2 (4): Klingeltaste 2 (potentialfrei)  
 CK (5): Gemeinsamer Kontakt Klingeltasten 1/2/3  
 TS (6): Steuerkontakt 1 (Anrufbeantwortung "6") max. 0,5 A/24 Vac/dc  
 C2 (7): Gemeinsamer Kontakt Steuerkontakte TS/TO max. 0,5 A/24 Vac/dc  
 oder Klingeltaste 3 (potentialfrei)  
 TO (8): Steuerkontakt 2 (Türöffner "7") max. 0,5 A/24 Vac/dc  
 A/B (A/B): Analoge Telefonleitung 600 Ohm  
 D3 (C): Steuerkontakt 5 (Steuerung "0") max. 1 A/24 Vac/dc  
 D2 (D): Steuerkontakt 4 (Steuerung "9") max. 1 A/24 Vac/dc  
 D1 (E): Steuerkontakt 3 (Steuerung "8") max. 1 A/24 Vac/dc  
 C1 (F): Gemeinsamer Kontakt Steuerkontakte D1/D2/D3 max. 1 A/24 Vac/dc  
 und Steuerkontakte TS/TO max. 0,5 A/24 Vac/dc bei 3 Klingeltasten  
 V/V' (G/H): Stromversorgung max. 12 Vac/dc max. 100 mA

## **GB** Doormaster Smart FTZ connections

NF/NF' (1/2) : speech 600 Ohm  
 K1 (3): chime button 1 (powerless)  
 K2 (4): chime button 2 (powerless)  
 CK (5): common wire for chime buttons 1/2/3  
 TS (6): driver contact 1 (answer "6") max. 0,5 A/24 Vac/dc  
 C2 (7): common wire for driver contacts TS/TO max. 0,5 A/24 Vac/dc  
 or chime button 3 (powerless)  
 TO (8): driver contact 2 (door opener "7") max. 0,5 A/24 Vac/dc  
 A/B (A/B): to analogue telephone line FXS 600 Ohm  
 D3 (C): driver contact 5 (controller "0") max. 1 A/24 Vac/dc  
 D2 (D): driver contact 4 (controller "9") max. 1 A/24 Vac/dc  
 D1 (E): driver contact 3 (controller "8") max. 1 A/24 Vac/dc  
 C1 (F): common wire for driver contacts D1/D2/D3 max. 1 A/24 Vac/dc  
 and driver contacts TS/TO max. 0,5 A/24 Vac/dc with 3 chime buttons  
 V/V' (G/H): power supply max. 12 Vac/dc max. 100 mA

## **I** Doormaster Smart FTZ morsetti

NF/NF' (1/2) : parla/ascolta 600 Ohm  
 K1 (3): chiamata 1 (contatto pulito)  
 K2 (4): chiamata 2 (contatto pulito)  
 CK (5): filo comune per chiamate 1/2/3  
 TS (6): comando 1 (risposta "6") max. 0,5 A/24 Vac/dc  
 C2 (7): filo comune per comandi TS/TO max. 0,5 A/24 Vac/dc  
 o chiamata 3 (contatto pulito)  
 TO (8): comando 2 (apri porta "7") max. 0,5 A/24 Vac/dc  
 A/B (A/B): verso la linea telefonica analogica 600 Ohm  
 D3 (C): comando 5 (funzione "0") max. 1 A/24 Vac/dc  
 D2 (D): comando 4 (funzione "9") max. 1 A/24 Vac/dc  
 D1 (E): comando 3 (funzione "8") max. 1 A/24 Vac/dc  
 C1 (F): filo comune per comandi D1/D2/D3 max. 1 A/24 Vac/dc  
 e comandi TS/TO max. 0,5 A/24 Vac/dc con 3 chiamate  
 V/V' (G/H): alimentazione max. 12 Vac/dc max. 100 mA

Quickmarks. Download reader for mobile phone: <http://www.quickmark.com.tw/En/basic/download.asp>



Bedienungsanleitung  
 Doormaster Smart  
 komplett, deutsch